

**The President and Fellows of Harvard College**  
**Harvard School of Public Health/François-Xavier Bagnoud Center for Health**

---

Towards the Development of a Human Rights Impact Assessment for the Formulation and Evaluation of Public Health Policies

Author(s): Lawrence Gostin, Jonathan M. Mann and Larry Gostin

Reviewed work(s):

Source: *Health and Human Rights*, Vol. 1, No. 1 (Autumn, 1994), pp. 58-80

Published by: [The President and Fellows of Harvard College](#), on behalf of [Harvard School of Public Health/François-Xavier Bagnoud Center for Health](#)

Stable URL: <http://www.jstor.org/stable/4065262>

Accessed: 11/01/2013 10:58

---

Your use of the JSTOR archive indicates your acceptance of the Terms & Conditions of Use, available at <http://www.jstor.org/page/info/about/policies/terms.jsp>

JSTOR is a not-for-profit service that helps scholars, researchers, and students discover, use, and build upon a wide range of content in a trusted digital archive. We use information technology and tools to increase productivity and facilitate new forms of scholarship. For more information about JSTOR, please contact support@jstor.org.



*The President and Fellows of Harvard College and Harvard School of Public Health/François-Xavier Bagnoud Center for Health are collaborating with JSTOR to digitize, preserve and extend access to *Health and Human Rights*.*

<http://www.jstor.org>

## A b s t r a c t

*All governmental policies in general, and health policies in particular, have the potential to burden human rights to a greater or lesser degree, whether by restricting freedoms, discriminating against individuals or population groups, or other mechanisms. While the protection of public health may in some cases outweigh concerns relating to human rights burdens, there are many instances where human rights are needlessly infringed. This article proposes a Human Rights Impact Assessment Tool that allows policy makers and human rights advocates to identify potential human rights burdens posed by public health policies and suggests strategies for ameliorating those burdens.*

---

*Todas las políticas gubernamentales en general, y en particular aquellas concernientes a la salud pública, pueden potencialmente transgredir los derechos humanos en mayor o menor medida, ya sea a través de la restricción de libertades, la discriminación contra individuos o grupos de población, o a través de otros mecanismos. Aunque la protección de la salud pública puede en muchos casos tener prioridad sobre la preocupación por la transgresión de los derechos humanos, en muchas ocasiones los derechos humanos son innecesariamente violados. Este artículo propone un Instrumento para Evaluar el Impacto sobre los Derechos Humanos que permita a los creadores de políticas gubernamentales y a los defensores de los derechos humanos identificar posibles maneras en que las políticas de salud pública puedan transgredir innecesariamente los derechos humanos. Se sugieren también estrategias para aminorar estas transgresiones.*

---

*Toutes les politiques gouvernementales en général et les politiques de la santé en particulier ont à des degrés différents, le potentiel de restreindre les droits de l'homme, que ce soit en limitant les libertés, en discriminant des individus ou des groupes entiers de la population ou encore en utilisant d'autres mécanismes. La protection de la santé publique peut en certaines circonstances l'emporter sur les considérations relatives aux restrictions des droits de l'homme. Cependant maintes fois ces derniers sont inutilement transgressés. Cet article présente un "Instrument d'Evaluation de l'Impact sur les Droits de l'Homme" permettant aux responsables politiques et aux promoteurs des droits de l'homme d'identifier les atteintes potentielles aux droits de l'homme conséquentes aux politiques de la santé. Des stratégies en vue d'améliorer ces indésirables conséquences sont finalement suggérées.*

# TOWARDS THE DEVELOPMENT OF A HUMAN RIGHTS IMPACT ASSESSMENT FOR THE FORMULATION AND EVALUATION OF PUBLIC HEALTH POLICIES

*Lawrence Gostin, JD, LLD (hon.)  
Jonathan M. Mann, MD MPH*

Public health policies are sometimes formulated without careful consideration of the goals of the policy, whether the means adopted will achieve those goals, and whether intended health benefits outweigh financial and human rights burdens. In particular, public health policies are seldom crafted with attention to their impact on human rights or the norms of international human rights law.<sup>1</sup> Implementing public health policies without seriously considering their human rights dimension may harm the people affected and render the policy ineffective, and possibly detrimental.<sup>2</sup>

The absence of careful thought about the human rights implications of health policies is not surprising: few public health officials are familiar with human rights doctrines, and even those who are may lack the skills and knowledge to assess a policy from a human rights perspective. At the same time, the human rights community has rarely written or litigated in the area of public health.<sup>3</sup> Even so fundamental a human rights concept as the right to health has not been operationally defined, and no

---

*Lawrence Gostin is Professor of Law, Georgetown University Law Center; Professor of Health Policy, the Johns Hopkins School of Hygiene and Public Health; Director, the Johns Hopkins/Georgetown Program on Law and Public Health. Jonathan Mann is François-Xavier Bagnoud Professor of Health and Human Rights and Professor of Epidemiology and International Health at the Harvard School of Public Health. Address correspondence to Lawrence Gostin, Georgetown University Law Center, 600 New Jersey Ave. NW, Washington, DC, 20001-2022 USA.*

organized body of jurisprudence exists to describe the parameters of that right.<sup>4</sup> The absence of an analytic tool that public health and human rights experts can apply to assess systematically the impact of public health policies on human rights has impeded development of collaborative scholarship and action in the fields of human rights and public health.

This article proposes a “human rights impact assessment”—an instrument to help evaluate the effects of public health policies on human rights and dignity. The basic steps outlined in this assessment tool may help those working in the public health domain to develop effective strategies that respect human rights. The human rights impact assessment should also assist human rights organizations and community-based groups in arguing for incorporation of human rights standards into public health thinking and policies. To illustrate the human rights impact assessment, this article draws on recent experience with sexually transmitted diseases (STDs),<sup>5</sup> human immunodeficiency virus (HIV) infection,<sup>6</sup> and tuberculosis (TB).<sup>7</sup>

### **Background: Note on Fact-Finding**

Assessment is one of the primary functions of public health. Careful gathering of all relevant information, provided through the perspectives of various disciplines (e.g., epidemiology, virology, medicine, nursing, social services) is a fundamental prerequisite for effective public policy development. Assessments of the human rights dimensions of policy likewise require rigorous and impartial fact-finding.

Institutions that seek to justify public health strategies (such as Ministries of Health, Environment, or Justice) may present seemingly credible arguments based on “hard evidence.” However, a set of “facts” presented by the government may be incomplete or biased. Proper fact-finding requires broad-based consultation with international agencies, non-profit organizations, public health or other professional associations, community-based or advocacy groups, and community leaders, who can provide invaluable perspective regarding how health policies affect human rights in their communities.<sup>8</sup> Discussions with individuals affected by the policy, and their advocates, are particularly important. When consulting these sources, special efforts should be made to gather material representing all viewpoints, to ensure a balanced picture.

## **Human Rights Impact Assessment**

The assessment involves a series of questions designed to balance the public health benefits of a policy against its human rights burdens.

### **Step I: Clarify the Public Health Purpose**

A clear understanding of the public health purpose to be achieved is essential. Government has a responsibility to articulate this public health purpose. Claims, for instance, that the objective is to combat tuberculosis, AIDS, or some other prevalent disease are too vague and overbroad. A precise conceptualization of purpose will more likely lead to sound, properly conceived policies. Examples of narrowly defined public health goals include: (1) prevention of HIV transmission through blood and blood products (through donor deferral, HIV screening, and heat treatment of blood products for people with hemophilia); or (2) prevention of tuberculosis transmission (by assuring compliance with treatment through directly monitored therapy).

Clearly articulated goals help to identify the true purpose of the intervention; facilitate public understanding and debate around legitimate health purposes; and reveal prejudice, stereotypical attitudes, or irrational fear.

### **Step II: Evaluate Likely Policy Effectiveness**

Existence of a valid—even compelling—public health objective does not justify a policy. Public officials have the burden of showing that the means used are reasonably likely to achieve the stated purpose.

Step II requires an honest, rigorous investigation into a policy's potential effectiveness. This requires a careful and impartial examination of the facts and expert opinion, as well as consultation with the groups affected.

It may be argued that certain public health decisions must be made in an emergency, precluding deliberative reasoning and assessment of scientific evidence. Public health necessity, however, does not absolve the actor from basing judgments on all available data. Public health emergencies, like other urgent situations, require rapid and rigorous assessment of the available data.<sup>9</sup>

Several questions may help guide further thinking about the potential effectiveness of a proposed public health policy. Following are examples that have been selected from screening programs for STDs, HIV, and mycobacterium tuberculosis.

(A) *Is the screening program appropriate and accurate?*

No screening test is 100 percent sensitive (meaning that all people with the condition have a positive test) and 100 percent specific (meaning that all people without the condition have a negative test). In addition to the inherent characteristics of testing methods, there are several important sources of potential problems: (1) human error, including improper manufacture or storage of laboratory reagents; (2) biological characteristics of the condition (i.e., for HIV infection, there is a several weeks' long "window" between infection and appearance of detectable antibodies); and (3) epidemiological characteristics, such as the prevalence of the condition in the population to be tested. Generally, given imperfect specificity of the test itself, the lower the prevalence of the infection in the population, the smaller the probability that a positive test accurately indicates that the person has the condition of interest. Therefore, screening low prevalence populations leads to substantial potential for "false positive" tests. The technical capability of the test cannot be separated from the specific context in which it is used.

(B) *Is the intervention likely to be effective?*

The fact that a government establishes an aggressive program for screening, partner notification, or isolation does not necessarily mean it is "doing something" about the problem. The real issue is whether the policy leads to effective action.

With regard to screening programs, it is important to determine the marginal value of any test results. That is, given what is already known about the patient or population, does the test yield new, useful information? More importantly, does the policy respond effectively to that information?

If a government, for example, conducts a widespread screening program for STDs in acute care hospitals, prisons, or brothels in order to prevent transmission, the policy must be examined carefully to see whether it succeeds in achieving its objective. If the program is not also designed to provide prevention services (such as education and counselling) or if there is no follow-up with treatment, the program will have identified cases of infection, but failed to intervene effectively. Screening, then, emerges as a constructive policy only if the information is demonstrably used for public health benefit.

It is sometimes misguidedly stated that gathering infor-

mation about health status in a population is always beneficial. While screening can provide useful data, its validity or generalizability may be biased or flawed. A more reliable understanding of disease prevalence in a population can be obtained through epidemiological research methods.

(C) *Is there a better approach?*

The proposed policy should be compared with other alternatives. Certainly, exploration of a wide range of more humane policies brings with it a fresh perspective. Consider an example involving commercial sex workers and people who have multiple sex partners. Coercive or punitive interventions alienate these communities, even driving them away from health care providers and counsellors who can help alter their high-risk behaviors. Instead of punitive measures, health officials could attempt to empower those women who may be impoverished, in abusive relationships, and unable to refuse sexual intercourse or demand that their partners use a condom. At the same time, public officials might work to meet employment, housing, health, and social needs of women to promote a lifestyle that respects their dignity as individuals and does not exploit them.<sup>10</sup>

Public policy development provides an avenue for improving community health. A hasty decision to pursue comprehensive programs of screening, contact tracing, or coercive measures imposes more than financial and human rights burdens: there are also opportunity costs. That is, devoting resources to one policy or service costs a government the opportunity to introduce other, potentially more effective, policies or services. The global community cannot afford to forego cost-effective measures that prevent disease and promote access to care.

In sum, a thoughtful exploration of these questions can benefit both public health and human rights: Is the form of intervention appropriate and accurate? Is the intervention likely to lead to effective action? Is a particular policy as effective as other feasible options?

**STEP III: Determine Whether the Public Health Policy Is Well-Targeted**

Well-conceived policies target the population in need. Ideally, public health strategies are tailored for those who will benefit from them. Thus, every policy creates a class of people to whom the policy applies and a class to whom it does not. For

example, screening policies may target a specific group such as homeless persons, drug users, foreigners, commercial sex workers, or prisoners. A policy of isolating all persons with TB who do not complete the full course of treatment may primarily affect poor persons who have inadequate access to health care services. A policy that appears neutral may, in fact, disproportionately impact certain groups in society. Recognizing that all policies create classifications that may discriminate against disfavored people is crucial. This awareness sensitizes the public health community to human rights concerns and helps to ensure that classifications are strictly related to public health needs. Policies that target individuals because of their race, sex, religion, national origin, sexual orientation, economic status, disability, or homeless status often stem from invidious stereotypes.

Sound public health policies must avoid both under- and over-inclusiveness.<sup>11</sup> A policy is under-inclusive when it reaches some, but not all, of the persons it ought to reach. By itself, under-inclusiveness is not necessarily a problem; a government may use its limited resources to address part of a public health problem. For example, a government's provision of disease prevention and treatment services (e.g., safe sex education, condom distribution, and health care) may be targeted to street children, but not to school children or adults. The under-inclusiveness of this policy does not necessarily reflect discrimination; it may simply indicate that particular country's public health problems and priorities.

This form of permissible under-inclusion is shown in Diagram 1. Population A represents all adolescents at risk for STDs and unwanted pregnancies who could benefit from sex education and counselling. Population B represents all adolescents in institutional settings, such as prisons, foster homes, and mental hospitals (including both institutionalized adolescents and those in schools and the wider community). The proposed public health policy would provide comprehensive sex education and condom distribution to Population B only; this policy is based on the assumption that parents of all other adolescents will provide them with appropriate information, and when resources become available, the health education program will be extended. While this approach is not ideal, it does not necessarily raise fundamental problems of invidious under-inclusion.<sup>12</sup>

However, certain under-inclusive policies may mask



### **Diagram 1: Permissible Under-Inclusion**

Proposed policy: Provide comprehensive sex education and condom distribution only to population B.

 = Target Populations

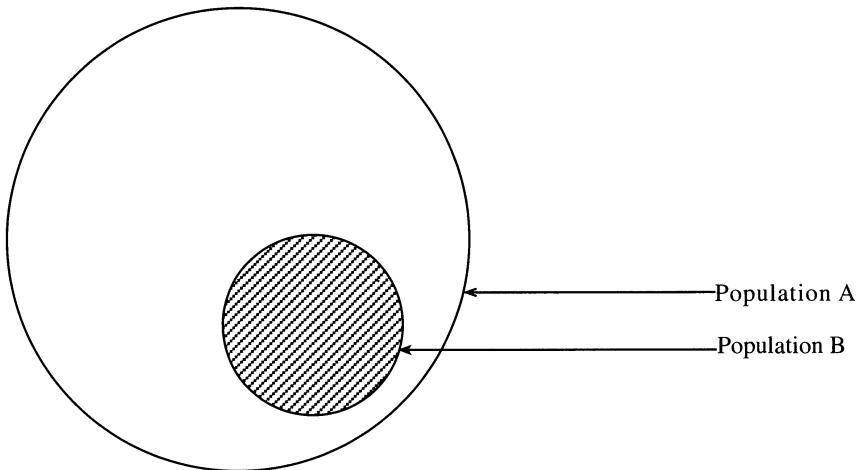

Population A= All adolescents at risk for STDs and unwanted pregnancies who could benefit from sex education and counseling.

Population B= All adolescents in institutional settings such as prisons, fosters homes, and mental hospitals.

discrimination—such as when a government uses coercive powers to target politically powerless and vulnerable groups, but not others that engage in similar behavior. The government is not obliged to devise policies that address the entire population with the potential to transmit disease. It may, instead, choose to address a public health problem one step at a time. However, if the sub-population targeted for coercion or punishment is chosen for reasons not directly related to public health, the under-inclusion is impermissible.

Diagram 2 illustrates such impermissible under-inclusion. Population A includes all persons diagnosed with active tuberculosis. Those persons who are included in Population A,

(but not B) are mostly middle- to upper-income individuals in the dominant ethnic community. Population B includes all homeless persons diagnosed with active tuberculosis, and is composed solely of people in the lowest socio-economic class, over 90 percent of whom are members of ethnic minorities. A policy of isolation during the active phase of the disease and directly observed therapy during the entire course of the treatment, if applied only to Population B, is invidious because it makes prejudicial, unsupported assumptions about persons in the two populations. Public health officials assume that persons in Population A will remain voluntarily isolated in their homes during the active phase and can be trusted to take the full course of their medication.

**Diagram 2: Impermissible Under-Inclusion**

Proposed Policy: Isolation during the active phase of tuberculosis and directly observed therapy during the entire course of the treatment of persons in population B.

 = Target Populations

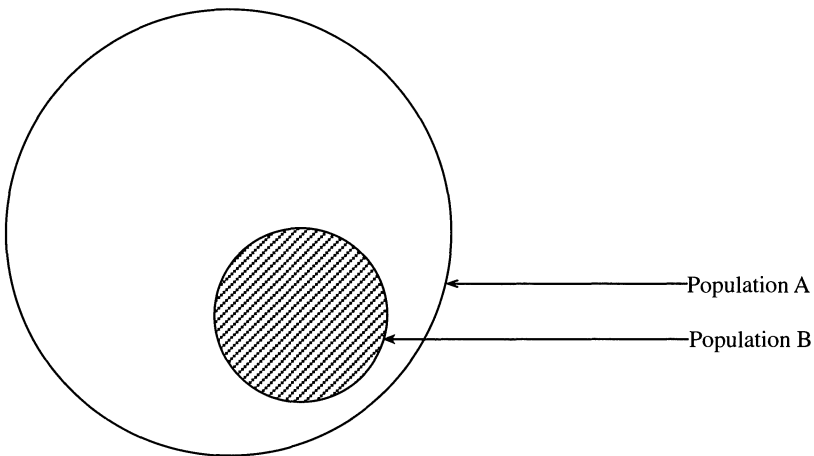

Population A= All persons diagnosed with active tuberculosis.

Population B= All persons without a permanent address diagnosed with active tuberculosis.

Officials also assume that persons in Population B will not voluntarily remain isolated, will fail to complete the full course of the medication, and will knowingly remain in crowded areas exposing others to infection. These assumptions are based, in part, upon generalizations about populations that separate individuals by their socio-economic class and race.

Even if the government policies are offering beneficial services, rather than coercion, they still may be impermissibly under-inclusive. For example, providing health care services to, or running clinical trials for, men but not women, may reflect society's neglect of women rather than legitimate public health priorities.

Over-inclusiveness occurs when a policy extends to more people than necessary to achieve its objective. Over-inclusiveness may not be cost-effective, as when counselling all persons entering acute care hospitals about HIV infection.

However, over-inclusiveness with regard to a coercive power is almost always unacceptable. Impermissively over-inclusive policies impose compulsory measures on groups *assumed* to be at high risk of transmitting disease; however, many individuals in the group pose no risk at all to the public. Compulsory measures that apply to all homosexuals, commercial sex workers, intravenous drug users, or foreigners from countries with high rates of HIV stem from the erroneous belief that all members of the group will engage in unprotected sex or needle-sharing.

Diagram 3, based upon the quarantine of HIV-infected persons in Cuba, illustrates such over-inclusion. Population A includes all persons infected with HIV in Cuba. Population B represents HIV-infected persons who engage in high-risk behavior. The quarantine policy targets all individuals in Population A, even though only a small percentage of this population is likely to transmit infection. While the policy may be effective as a public health measure, it deprives many people of liberty who pose no risk to society.

Policies may be both under- and over-inclusive. Such policies affect individuals who do not pose a danger to the public (over-inclusiveness), yet fail to include individuals who would pose a danger (under-inclusiveness). For example, criminal penalties against commercial sex workers but not their male agents or clients is both under- and over-inclusive. The policy is suspiciously under-inclusive because it selectively punishes a vulner-

able population when at least two other groups participate in the risky behavior. (It also excludes all others who have sex and fail to inform their partners of their infection.) The policy is also over-inclusive because there are some sex workers who are not infected with an STD; inform clients of the potential risks; and/or practice safer sex.

Diagram 4 provides another illustration of over- and under-inclusion. Population A represents all foreigners entering the

**Diagram 3: Over-Inclusion**

Proposed Policy: Quarantine of all HIV positive persons in the country.

 = Target Populations

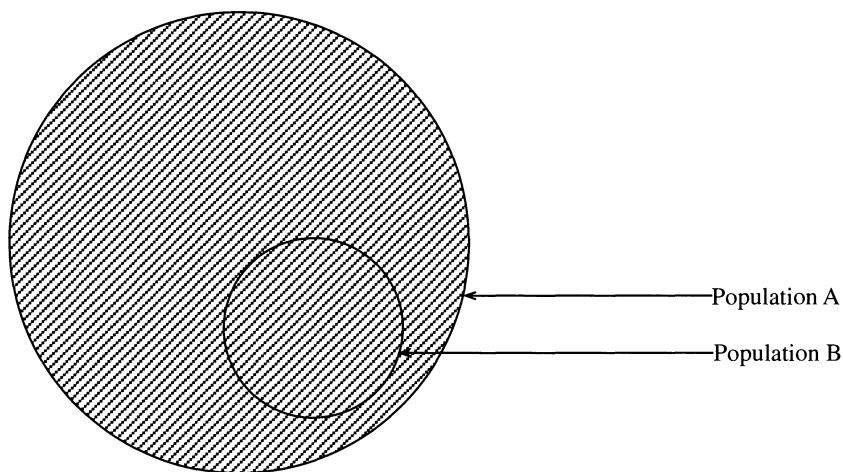

Population A= All persons with HIV in the country.

Population B= All persons with HIV who engage in high-risk behavior.

country. Population B represents all foreigners entering the country from Region X. Population C represents all foreigners entering the country from Region X who would engage in high-risk behavior. Population D represents all foreigners entering the country from outside Region X who would engage in high-risk behavior. The proposed policy of screening and excluding those who

test positive for HIV infection is targeted to Population B only (foreigners from Region X). Such a policy is overbroad because, while some infected individuals in Population B may engage in high-risk behaviors, many group members are not infected, and many infected people will act responsibly. At the same time, the policy does not apply to foreigners outside of Region X, even though many of them are infected with HIV and may engage in high-risk behavior.<sup>13</sup>

**Step IV: Examine Each Policy for Possible Human Rights Burdens**

Having considered several important dimensions of public health policy-making, it is now possible to examine the human rights impact of a proposed policy. The human rights impact as-

**Diagram 4: Under- and Over-Inclusion**

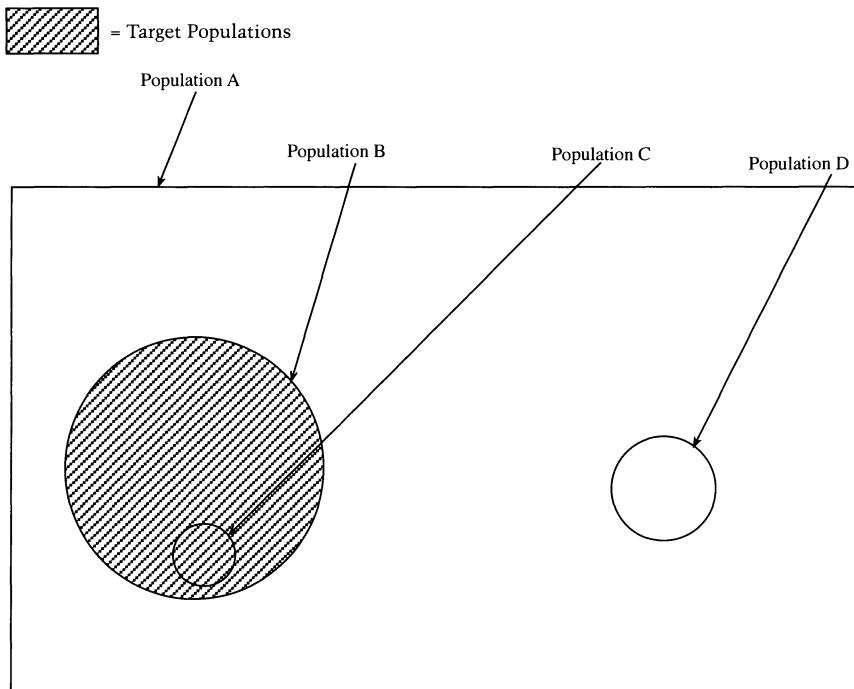

Population A=All foreigners entering the country.  
 Population B=All foreigners from region X.  
 Population C=All foreigners from region X with high-risk behaviors.  
 Population D=All foreigners from outside region X with high-risk behaviors.

assessment involves a meticulous balancing of the potential benefits to the health of the community with repercussions of the policy for human rights. Human rights burdens may outweigh even a well-designed policy. Identifying all potential infringements on human rights and evaluating those likely to occur will contribute to sound government action.

The International Bill of Human Rights<sup>14</sup> may be considered the source of basic human rights. These documents list and describe human rights, recognize duties of individuals to the community,<sup>15</sup> create non-derogable rights that may not be infringed even in times of public emergency, and provide criteria for the limitation of other rights.

Certain human rights are so essential to the dignity and well-being of people that they are considered absolute. These rights must never be infringed, even if the country is in a declared state of public emergency and the public health need is extraordinarily strong. Non-derogable rights include freedom from discrimination; the right to life; freedom from torture and from cruel, inhuman or degrading treatment or punishment; freedom from slavery or involuntary servitude; freedom from imprisonment for failure to fulfill contractual obligations; freedom from retroactivity for criminal offenses; the right to recognition as a person before the law; and freedom of thought, conscience, and religion.<sup>17</sup> Thus, from this perspective, the public health benefits of policies that burden non-derogable human rights never outweigh the intrusion on human rights. In short, the fact that a policy improves public health does not justify any possible means to achieve that end.

Other rights may be restricted in certain situations. Article 29 of the Universal Declaration states that limitations of these rights must be "determined by law solely for the purpose of securing due recognition and respect for the rights and freedoms of others and of meeting the just requirements of morality, public order and the general welfare in a democratic society." Generally speaking, restrictions on human rights must be: (i) *prescribed by law in a democratic society*—the restriction on rights must be based upon the thoughtful consideration of the legislature; and (ii) *necessary to protect a valued social goal*—the legislature must be promoting a compelling public interest such as safety or health. Restricting human rights is not to be taken lightly. Indeed, in most cases, coercive or punitive policies will

harm, not enhance, the health of the public.

Civil and political rights that may be infringed if necessary to protect a valued social goal include: the right to liberty and security of person; freedom from arbitrary arrest, detention or exile; freedom of movement; freedom from arbitrary interference with privacy, family, home and correspondence; the right to peaceful assembly and association; and freedom of opinion and expression, including the right to seek, receive and impart information. Minor infringements on human rights may be justified when the public health interest is compelling and there is no other way to achieve the objective. For example, requiring the immunization of a population by means of a safe and effective vaccine may undermine the right to security of person, but the substantial reduction in morbidity and mortality may justify the intervention.

Economic, cultural, and social rights do not have the same standing in international law as civil and political rights.<sup>16</sup> Rights afforded in the International Covenant on Economic, Social and Cultural Rights (ICESCR) include the right to work (Article 6), to social security (Article 9), to an adequate standard of living including adequate food, clothing and housing (Article 11), to the enjoyment of the highest attainable standard of physical and mental health (Article 12), to education (Article 13), and to enjoyment of the benefits of scientific progress and its applications (Article 15). Economic, social, and cultural rights are not immediately enforceable and the United Nations Committee on Economic, Social, and Cultural Rights does not have power to require compliance. However, Article 2 of the ICESCR imposes an obligation on state parties to take steps, individually and through international assistance and co-operation, especially economic and technical, to the maximum of its available resources, with a view to progressive realization of these rights.

How can a human rights burden created by a public health policy be measured? Four factors may be considered: (1) the nature of the human right; (2) the invasiveness of the intervention; (3) the frequency and scope of the infringement; and (4) its duration.

Policies that adversely affect fundamental rights and freedoms create significant burdens on human rights. A decision to imprison, isolate, or otherwise restrict a person's liberty substantially impacts the person's life. In contrast, while partner notifi-

cation requirements potentially infringe on privacy, this type of invasion is usually less grave than a deprivation of liberty.

The second factor involves the degree of intrusion on a particular right. Neither liberty nor privacy is an absolute right. All societies tolerate some incursions on these rights, such as limitations on individual liberty where its exercise would interfere with the fundamental rights of others, or disclosure of private information when strict confidentiality would pose an imminent danger to another person.<sup>18</sup> However, the burdens (harms) from public health measures that intrude on either right may well outweigh their potential benefits.

For example, a government's decision to record the names of individuals with certain diseases and to grant public access to the information seriously intrudes on privacy rights of the infected individuals. Similarly, prohibiting all women with HIV infection from bearing children based on the risk of perinatal HIV transmission fundamentally burdens privacy in the context of reproductive decision-making.

A third question asks whether the restriction of rights applies to a few people or to an entire group or population. A decision to isolate an individual with active, contagious tuberculosis is clearly justified. However, a policy that quarantines a large population of persons infected with *M. Tb.* substantially burdens human rights. The Cuban government, for example, has sought to reduce the transmission of HIV in its population by screening and isolating all Cubans returning from abroad. The government might plausibly argue that it would achieve a compelling public health objective, but the gravity and scope of the human rights burdens are prohibitive.<sup>19</sup>

Fourth, the duration of a human rights burden must be considered. Isolating a person infected with *M. Tb.* during the active stage of the disease is a necessary, short-term intervention. However, isolating a person with HIV infection is almost always inappropriate; it raises the prospect of indefinite duration since the person remains potentially infectious to others for his or her lifetime.<sup>20</sup>

Finally, legal and ethical standards strongly suggest that public health programs incorporate the principle of informed consent.<sup>21</sup> This doctrine is most clearly applicable to biomedical research, but may also include other health programs including



testing and treatment. Principle I of the Nuremberg Code<sup>22</sup> provides the definition of consent from which subsequent international ethical guidelines are derivative.<sup>23</sup>

The voluntary consent of the human subject is absolutely essential. This means that the person involved should have legal capacity to give consent; should be so situated as to be able to exercise free power of choice, without the intervention of any element of force, fraud, deceit, duress, over-reaching or other ulterior form of constraint or coercion; and should have sufficient knowledge and comprehension of the elements of the subject matter involved as to enable him to make an understanding and enlightened decision.

Thus, the consent of the human subject to research must be legally competent, voluntary, informed, and comprehending.<sup>23</sup> Article 7 of the International Covenant on Civil and Political Rights prohibits medical or scientific experimentation without the person's free consent.

The grounds for extending the principle of informed consent to treatment and the exercise of other public health powers is found in Article 9 of the International Covenant of Civil and Political Rights, which guarantees the right to security of person. Security of person may be taken to mean that persons have a right to determine for themselves how they will be treated.

Respect for personal autonomy underlies the doctrine of informed consent. The principle of autonomy requires that every competent human being has the right to make decisions regarding her health and well-being.<sup>25</sup>

The concept of informed consent is critically important to maintaining sound public health practice. Consent should be viewed as more of a process of communication and interaction with the patient than a stark legal requirement. The process of consent provides the opportunity to counsel and educate while it preserves the integrity of health professionals and the dignity of the patient.

Human rights experts and non-governmental organizations may invaluablely assist those trying to evaluate a public health policy's impact on human rights and to enforce international legal protections. Establishing networks of experts in human rights and public health can facilitate constructive discussions. This can only lead to greater respect for human rights in policy development, implementation, and enforcement.

**STEP V: Determine Whether the Policy Is the Least Restrictive Alternative That Can Achieve the Public Health Objective**

The human rights impact assessment suggests a balance between the burdens and public health benefits of a policy. In general, broad or intrusive human rights violations are seldom, if ever, warranted. At the extreme, a public health approach that uses an effective means to achieve a compelling public health objective may sometimes warrant a limitation of human rights. In contrast, a dubiously useful government policy deserves less weight in the balance.

A vital step in the human rights impact assessment is the examination of alternative policies that burden human rights to a lesser extent, while still protecting the health of the community. The principle of the least restrictive alternative seeks the policy that is least intrusive while achieving the public health objective as well or better than the policy under consideration. The human rights community should insist that governments find alternatives that achieve the public health goal without unduly violating rights and dignity.

Public health officials sometimes misunderstand the principle of the least restrictive alternative. The principle does not require governments to adopt ineffective policies or to forego effective policies. Rather, it proposes selective implementation of programs that are human rights-sensitive as well as equally or more effective in achieving a valuable public health goal. On rare occasions, less intrusive alternatives are also less effective, and the principle of the least restrictive alternative does not require their adoption.

To determine the least restrictive alternative, non-coercive approaches should first be considered; if noncoercive approaches are insufficient, gradual exploration of more intrusive measures are permissible where clearly necessary. For example, if the provision of service or benefits programs (e.g., counseling, education, and treatment) do not adequately protect the public health, more restrictive policies may be warranted.

Governments sometimes feel public pressure to respond to an urgent public health concern with restrictive or punitive measures. For example, public opinion may blame foreigners, drug users, homosexuals, sex workers or other disenfranchised populations for the health threat. A searching examination of a range of less restrictive alternatives can uncover policies that not only

defend the rights of the individual, but also are more worthwhile for the population as a whole.

Intense conflicts between public health and human rights occasionally arise, with members of the public or politicians claiming that it is necessary to “get tough” on persons who transmit disease. Actually, public health and human rights are usually in harmony: promotion of human rights is most protective of health and the best health strategies are respectful of the inherent dignity of the person. An overly coercive policy may discourage persons at risk from coming forward for testing, counseling or treatment. Health care professionals then lose contact with persons likely to spread disease, ultimately causing greater harm to the public. Moreover, public health and human rights goals are usually synergistic; protecting human rights encourages cooperation and a shared vision of the need for safer behaviors and thereby promotes public health.

In order to explore further the concept of the least restrictive alternative, consider the case of a large city seeking to slow the spread of multidrug-resistant tuberculosis. Public opinion may call for civil commitment or court-ordered directly observed therapy for all people with active TB. However, offering persons with tuberculosis incentives and services such as travel allowances, food, shelter, and child care may be more effective in helping them complete the full course of their medication than compulsory treatment or commitment.<sup>26</sup>

**Step VI: If a Coercive Public Health Measure Is Truly the Most Effective, Least Restrictive Alternative, Base It on the “Significant Risk” Standard**

After analyzing a range of policies, the health authority may conclude that a coercive approach is the most effective, least restrictive alternative. In this case, it should make an *individual determination* that the person poses a *significant risk* to the public.<sup>2</sup> The “significant risk” standard permits coercive measures only to avert likely harm to the health or safety of others. The determination of significant risk requires public health inquiry. The intent is to replace decisions based on irrational fear, speculation, stereotypes, or pernicious mythologies with reasoned, scientifically valid judgments.

Significant risk must be determined on a case-by-case basis by means of fact-specific, individual inquiries. Blanket rules or generalizations about a class of persons do not suffice.

For infectious diseases like HIV/AIDS or tuberculosis, the significant risk standard is based upon four factors: (i) nature of the risk (i.e. mode of transmission); (ii) probability of the risk (i.e., how likely is it that the transmission will occur); (iii) severity of harm (i.e., the harm to the person if the infection were transmitted); and (iv) duration of the risk (i.e., the length of time the person is infectious).

As for the nature of the risk, public health interventions must be based on epidemiologically supported modes of transmission. For example, epidemiologic evidence shows that the major routes of HIV transmission involve sexual intercourse and sharing contaminated drug injection equipment. Exclusion of HIV-infected children from school, for example, based on the fear of biting, spitting, or rough play in sports activities would not meet the significant risk test. Similarly, the possibility that people infected with HIV who handle food may bleed into it, or that airline pilots might have a sudden onset of AIDS dementia, is so low that it does not justify depriving a class of individuals of their rights and livelihood.

The risk to the public must be *probable*, not merely speculative or remote. Theoretically, for example, a person could transmit HIV by biting. But the actual risk is extremely low (approaching zero). To bring criminal charges for this behavior lacks a public health justification. The *harm* that results if the infection is transmitted must be substantial. However, even potential harms of great severity (e.g., HIV infection) do not justify coercion if the probability of transmission is exceedingly low. The "significant risk" requirement holds that, even though a disease can be serious or fatal, restrictions on individuals lack justification unless a reasonable probability of transmission exists. For example, some parents of school children have difficulty comprehending why officials can exclude children infested with hair lice from school, but not those infected with HIV. The "significant risk" standard is met in the former case because of the very high probability that other children will contract lice. In contrast, the risk of contracting HIV in that setting is highly remote.

Finally, regarding duration of risk, the person must be *currently contagious*. The significant risk standard allows coercion only during the period that the person poses a risk to the public. As soon as the risk subsides, the justification for coercion similarly subsides.

**STEP VII: If a Coercive Measure Is Truly Necessary to Avert a Significant Risk, Guarantee Fair Procedures to Persons Affected**

The fact that officials do not intend a public health intervention to be punitive would not alter the reality that it restricts personal liberty. International human rights standards require that governments provide a fair, public hearing before they deprive persons of liberty, freedom of movement, or other fundamental rights.

Examples of this process are well-described in the mental health context. The United Nations Principles for the Protection of Persons with Mental Illness and for the Improvement of Mental Health Care require procedural safeguards (“due process”) prior to civil commitment.<sup>28</sup> As in the mental health setting, public health policies that deprive people of liberty in order to protect the public must guarantee procedural justice.

The natural justice principle, as construed by the European Court of Human Rights, requires a hearing by a dispassionate decisionmaker, who is separate from the executive branch and the parties to the case.<sup>29</sup> Thus, an independent court or tribunal must adjudicate the dispute. The person whose liberty is threatened is entitled to advance notice of the hearing, representation, and an opportunity to present evidence.

Procedural safeguards are not merely formalistic. The aim is to ensure a more accurate fact-finding process and greater equity and fairness to individuals who face a loss of liberty. Hearings give public health officials the opportunity to review their general approach to the health problem as well as the human rights impact in an individual case.

A government that deprives an individual of liberty or other rights must provide a fair and public hearing. These substantive and procedural requirements of human rights help ensure that governments demonstrate the genuine necessity of compulsory measures to protect the community and preserve justice for the individual.

**Conclusion**

Public health programs that respect human rights will encourage individuals and communities to trust, and cooperate with, public health authorities. Promotion of human rights, particularly among previously disenfranchised groups, increases their ability to protect their own health. Finally, the right to health is a basic human right, related to and dependent on many other hu-

man rights. The Human Rights Impact Assessment described in this article provides a tool to achieve the best possible public health outcomes while protecting the human rights of individuals and populations.

*The Human Rights Impact Assessment evolved from work by a group of friends and colleagues working at the Harvard School of Public Health, including Dr. Katarina Tomasevski, Ms. Zita Lazzarini, and Ms. Sofia Gruskin, in addition to the authors. The goal of the Human Rights Impact Assessment is to provide public health practitioners, human rights advocates, community workers, and others interested in health policy, with a systematic approach to exploring the human rights dimensions of public health policies, practices, resource allocation decisions, and programs. The authors warmly acknowledge the expert assistance of Jean C. Allison in the conceptualization of this article, particularly the diagrams.*

## References

1. Public health policies are often crafted in the absence of clear rules of domestic law. See Institute of Medicine, *The Future of Public Health*, National Academy Press, Washington, DC, 1988; Gostin L, *The Future of Public Health Law*, *American J. of Law & Med.* 1987; 12:461-490.
2. There does exist an influential and growing literature that uses the disciplines of the philosophy of law and biomedical ethics for the evaluation of health policies. Influential jurisprudential analyses include those by Ronald Dworkin in his classic book, *Taking Rights Seriously* (Harvard University Press, Cambridge, MA, 1977), and in his more recent analysis of death and dying in *The Law's Empire* (Oxford University Press), 1993. See also, John Rawls, *A Theory of Justice*, Harvard University Press, Cambridge, MA, 1971. Some authors treat biomedical ethics and human rights as if they were the same subject. See, Eugene B. Brody, *Biomedical Technology and Human rights*, UNESCO, Paris, 1993. However, examination of health policy from a jurisprudential or ethical perspective, while important, is not a substitute for a human rights analysis. The human rights perspective is unique because it is based upon an organized set of internationally recognized and enforceable legal standards. See Philip Alston, ed., *The United Nations and Human Rights: A Critical Appraisal*, Clarendon Press, Oxford, 1992.
3. Major texts on human rights barely discuss the application of international law to public health. See e.g., Frank Newman & David Weissbrodt, *International Human Rights*, Anderson Publishing Co., Cincinnati, 1990). However, several excellent reports on the human rights impact of HIV infection have appeared. See Paul Sieghart, *AIDS and Human Rights*, British Medical Foundation, London, 1989; Tomasevski K, Gruskin S, Lazzarini Z, Hendriks A, *AIDS and Human Rights*. In: Mann J, Tarantola DJM, Netter TW, eds. *AIDS in the World 1992*, Harvard University Press, Cambridge, MA, 1992, pp. 537-573; *Rights and Humanity, The Rights and Humanity Declaration and Charter on HIV and AIDS*, The Hague, 1992.
4. A notable exception appears in this issue, Leary V, "The Right to Health,"

- Health and Human Rights*, 1994, 1:28. See, Committee on Economic, Social and Cultural Rights, Ninth Session, 22 November-10 December 1993, *Implementation of the International Covenant on Economic, Social and Cultural Rights: Day of General Discussion on the Right to Health* (6 December 1993), E/C.12/1993/WP.27.
5. See e.g., Allan Brandt, *No Magic Bullet: A Social History of Venereal Disease in the United States Since 1880* (Oxford University Press, New York), 1985, rev ed., 1987.
6. See e.g., Ronald Bayer, *Private Acts, Social Consequences: AIDS and the Politics of Public Health* (New Brunswick, N.J., Rutgers University Press), 1991.
7. See e.g., Sheila M. Rothman, *Living in the Shadow of Death: Tuberculosis and the Social Experience of Illness in American History* (Basic Books, N.Y.), 1994.
8. See e.g., Human Rights Watch, *World Report 1994*, Human Rights Watch 1994, New York; Amnesty International, *Report 1993*, London, 1993; Physicians for Human Rights, *Landmines: A Deadly Legacy* (Human Rights Watch, N.Y.), 1993; Human Rights Watch & the American Civil Liberties Union, *Human Rights Violations in the United States* (New York, Human Rights Watch & the American Civil Liberties Union), 1993.
9. Elaine Scarry, *Thinking in an Emergency*, Harvard University Press, 1993.
10. Hauserman J, *Ethical and Social Aspects of AIDS in Africa* (Commonwealth Secretariat, London), 1990.
11. The concept of under- and over-breadth is frequently used in Equal Protection analysis in the United States when the government infringes a fundamental right (such as the right to travel) or sets up a class based on race or some other suspect class. See generally, Laurence Tribe, *American Constitutional Law* 1446-1451 (Foundation Press, Mineola, N.Y., 2d ed.), 1988.
12. Under certain circumstances, however, the policy might deprive non-institutionalized adolescents of the right to education or the right to health. If these adolescents were at significant risk of contracting STDs and unwanted pregnancies, and the government systematically denied them the education necessary to avoid these harms, telling arguments could be made under the International Covenant of Economic, Social and Cultural Rights.
13. Gostin L, Cleary P, Mayer K et al, "Screening and exclusion of international travelers and immigrants for public health purposes: an evaluation of United States policy", *NEJM* 1990; 322:1743-1746.
14. The International Bill of Human Rights comprises the Universal Declaration of Human Rights (UDHR), the International Covenant of Civil and Political Rights (ICCPR), the International Covenant of Economic, Social and Cultural Rights (ICESCR), and the Optional Protocol to the International Covenant on Civil and Political Rights.
15. Article 29 of the Universal Declaration of Human Rights declares that "Everyone has duties to the community in which alone the free and full development of his personality is possible."
16. Article 4(2) of the International Covenant on Civil and Political Rights permits no derogation from articles 6, 7, 8 (paras. 1 and 2), 11, 15, 16, and 18 even in cases of declared national emergencies.
17. Alston P, The Committee on Economic, Social and Cultural Rights. In: *The United Nations and Human Rights: A Critical Appraisal* 471-508 (Clarendon Press, Oxford), 1992
18. Ankrah EM, Gostin LO, "Ethical and Legal Considerations of the HIV Epidemic in Africa". In: *AIDS in Africa* 547-558, Essex M, Mboup S, Kanki PJ, Kalengay MR, eds. (Raven Press, N.Y.), 1994.
19. Bayer R, Heaton C, "Controlling AIDS in Cuba: the logic of quaran-

- tine", *NEJM* 1989; 320:1022.
20. Wendy E. Parmet, "AIDS and Quarantine: The Revival of an Archaic Doctrine", *Hofstra L. Rev.* 1985;14:53-90.
21. Faden RR, Beauchamp TL, *A History and Theory of Informed Consent* (Oxford University Press), 1986.
22. Nuremberg Code 1947, reprinted from *Trials of War Criminals Before the Nuremberg Military Tribunals Under Control Council Law No. 10*, vol. 2, at 181-82 (1949). The Nuremberg Code was part of the judgment reached by the Nuremberg Court in *United States v. Karl Brandt, et al*, U.S. Adjutant General's Department, *Trials of War Criminals Under Control Council Law No. 10* (Oct. 1946 - April 1949), vol. 2, The Medical Case, (Washington D.C., U.S. Government Printing Office), 1947.
23. See, Declaration of Helsinki IV, I Basic Principles 9, 41st World Medical Assembly (1989); Council of International Organizations of Medical Sciences, *International Guidelines for Ethical Review of Epidemiological Studies* (CIOMS, Geneva), 1991.
24. Robert J. Levine, *Ethics and Regulation of Clinical Research* 98-99 (Yale University Press, New Haven), 1988.
25. Arnold J. Rosoff, *Informed Consent: A Guide for Health Care Providers* (Aspen Publishers, Rockville, MD), 1981.
26. Dubler NN, Bayer R, Landesman S, White A, *The Tuberculosis Revival—Individual Rights and Societal Obligation in a Time of AIDS* (United Hospital Fund, N.Y.), 1992.
27. This is similar to the standard used in the United States under the Americans with Disabilities Act. Gostin L, "Impact of the ADA on the Health Care System." In: *Implementing the Americans with Disabilities Act: Rights and Responsibilities of All Americans* 175-186, Gostin L, Beyer H, eds. (Brookes Publishing, Baltimore, Maryland), 1993.
28. United Nations, Principles for the Protection of Persons with Mental Illness and for the Improvement of Mental Health Care, G.A. Res. 119, U.N. GAOR, 46th Sess, Supp. No. 49, Annex, at 188-92, U.N. Doc. A/46/49 (1991).
29. X v. United Kingdom, European Court of Human Rights, Judgement given November 5, 1981. See Publications of the European Court of Human Rights, Series B: Pleadings, Oral Arguments and Documents, vol. 41, 1980-82, Case of X v. the United Kingdom, Council of Europe, 1985.